

# Datasheet P-502CI

## Industrial Style (IP65) Digital Pressure Meter

### > Introduction

High-Tech model P-502CI digital electronic pressure meters have a well-proven compact thru-flow design. The instruments include a diaphragm type piezo-resistive pressure sensor for pressure measurement. The pressure meter performs with high accuracy and repeatability. The industrial style (IP65) IN-PRESS model P-502CI can optionally be combined with a close-coupled control valve to act as a “back pressure controller” for upstream ( $P_1$ ) pressure control or a “forward pressure controller” for downstream ( $P_2$ ) pressure control.

### > Technical specifications

#### Measurement / Control system

Accuracy (incl. linearity and hysteresis)	: $\pm 0,5\%$ of full scale (FS)
Pressure rangeability	: 1 : 50 for pressure meter; 1 : 20 for P2-control; 1 : 5 for P1-control
Repeatability	: $\leq 0,1\%$ RD
Response time sensor	: 2 msec
Operating temperature	: $-10 \dots +70^\circ\text{C}$
Temperature sensitivity	: $0,1\%$ FS/ $^\circ\text{C}$
Leak integrity	: tested $< 2 \times 10^{-9}$ mbar l/s He
Attitude sensitivity (at $90^\circ$ change)	: $< 0,3$ mbar
Warm-up time	: negligible

#### Mechanical parts

Material (wetted parts)	: stainless steel 316L or comparable
Process connections	: compression type or face seal couplings
Seals	: standard : Viton options: EPDM, FFKM (Kalrez)
Ingress protection (housing)	: IP65

#### Calibration

References verified by an ISO 17025 calibration laboratory, directly traceable to Duchth and international standards.

*Although all specifications in this datasheet are believed to be accurate, the right is reserved to make changes without notice or obligation.*

#### IN-PRESS Pressure Meter model P-502CI

#### Electrical properties

Power supply	: $+15 \dots 24$ Vdc
Power consumption	: max. 385 mA; add 50 mA for Profibus, if applicable
Analog output	: $0 \dots 5$ (10) Vdc, min. load impedance $> 2$ k $\Omega$ ; 0 (4) $\dots 20$ mA (sourcing), max. load impedance $< 375$ $\Omega$
Analog setpoint (for EPT + control valve)	: $0 \dots 5$ (10) Vdc, min. load impedance $> 100$ k $\Omega$ ; 0 (4) $\dots 20$ mA, load impedance $\sim 250$ $\Omega$
Digital communication	
Standard (8 DIN male conn.)	: RS232
By optional interface board	: Profibus-DP <sup>®</sup> , DeviceNet <sup>™</sup> , Modbus-RTU, FLOW-BUS
Electrical connection	
Analog/RS232	: 8 DIN connector (male)
Profibus-DP <sup>®</sup>	: bus: 5-pin M12 connector (female); power: 8 DIN connector (male)
DeviceNet <sup>™</sup>	: 5-pin M12-connector (male)
Modbus-RTU/FLOW-BUS	: 5-pin M12-connector (male)

### > Sensor codes, ranges and burst pressure

Sensor code	Pressure ranges	Burst pressure
350A (Absolute pressure)	100 ... 350 mbara	1,4 bara
1K1A .. ..	0,35 ... 1,1 bara	3,1 bara
6K0A .. ..	1,1 ... 6bara	10,5 bara
20KA .. ..	6 ... 20 bara	62 bara
M10A .. ..	20 ... 64 bara	200 bara
350R (Relative pressure)	100 ... 350 mbarg	1,4 barg
1K1R .. ..	0,35 ... 1,1 barg	3,1 barg
6K0R .. ..	1,1 ... 6 barg	10,5 barg
20KR .. ..	6 ... 20 barg	62 barg

Архангельск (8182)63-90-72  
Астана +7(7172)727-132  
Астрахань (8512)99-46-04  
Барнаул (3852)73-04-60  
Белгород (4722)40-23-64  
Брянск (4832)59-03-52  
Владивосток (423)249-28-31  
Волгоград (844)278-03-48  
Вологда (8172)26-41-59  
Воронеж (473)204-51-73  
Екатеринбург (343)384-55-89  
Иваново (4932)77-34-06  
Ижевск (3412)26-03-58  
Иркутск (395) 279-98-46  
Киргизия (996)312-96-26-47

Казань (843)206-01-48  
Калининград (4012)72-03-81  
Калуга (4842)92-23-67  
Кемерово (3842)65-04-62  
Киров (8332)68-02-04  
Краснодар (861)203-40-90  
Красноярск (391)204-63-61  
Курск (4712)77-13-04  
Липецк (4742)52-20-81  
Магнитогорск (3519)55-03-13  
Москва (495)268-04-70  
Мурманск (8152)59-64-93  
Набережные Челны (8552)20-53-41  
Нижний Новгород (831)429-08-12  
Казахстан (772)734-952-31

Новокузнецк (3843)20-46-81  
Новосибирск (383)227-86-73  
Омск (3812)21-46-40  
Орел (4862)44-53-42  
Оренбург (3532)37-68-04  
Пенза (8412)22-31-16  
Пермь (342)205-81-47  
Ростов-на-Дону (863)308-18-15  
Рязань (4912)46-61-64  
Самара (846)206-03-16  
Санкт-Петербург (812)309-46-40  
Саратов (845)249-38-78  
Севастополь (8692)22-31-93  
Симферополь (3652)67-13-56  
Таджикистан (992)427-82-92-69

Смоленск (4812)29-41-54  
Сочи (862)225-72-31  
Ставрополь (8652)20-65-13  
Сургут (3462)77-98-35  
Тверь (4822)63-31-35  
Томск (3822)98-41-53  
Тула (4872)74-02-29  
Тюмень (3452)66-21-18  
Ульяновск (8422)24-23-59  
Уфа (347)229-48-12  
Хабаровск (4212)92-98-04  
Челябинск (351)202-03-61  
Череповец (8202)49-02-64  
Ярославль (4852)69-52-93

## > Model number identification

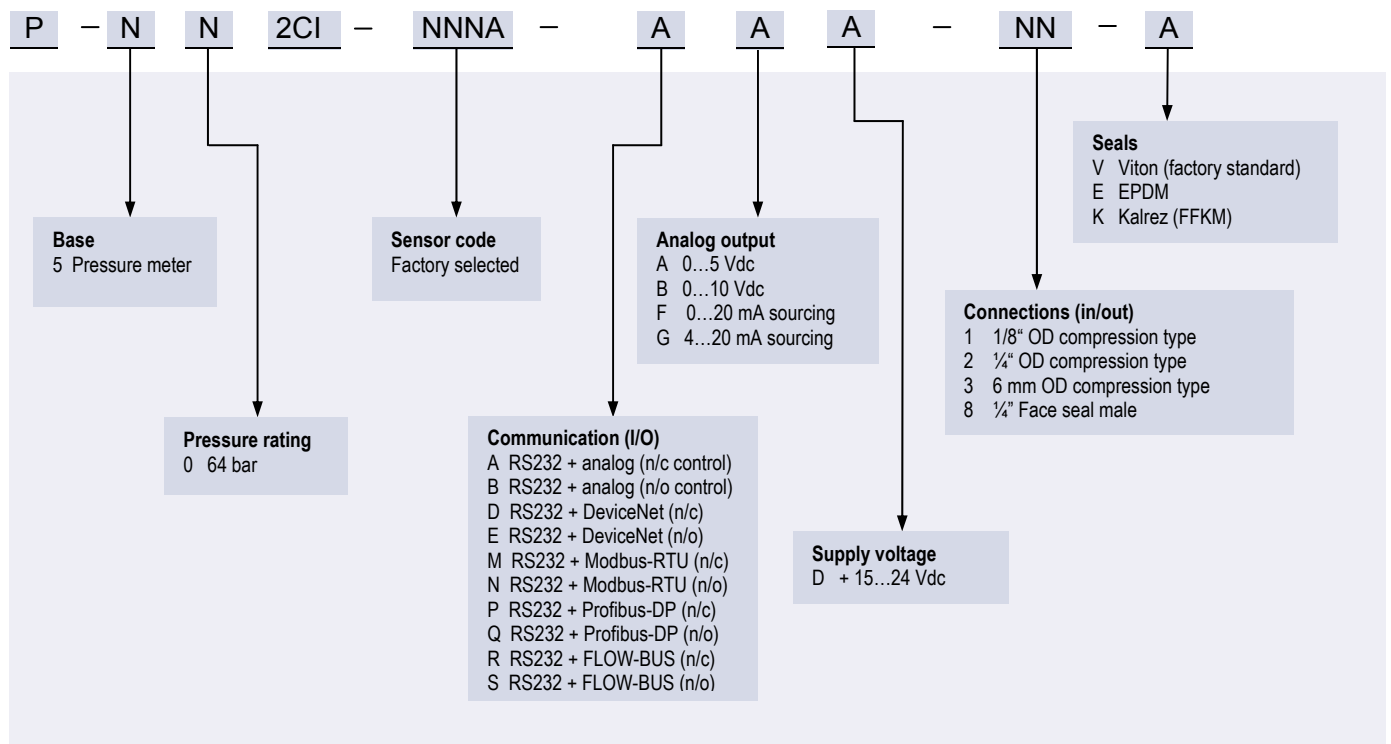

## > Measuring principle

The Bronhorst High-Tech IN-PRESS pressure sensor is a piezo-resistive bridge on the surface of a silicon chip, with a pressure diaphragm, whose thickness determines the pressure range. When a pressure acts on this chip, the diaphragm flexes, and the resistor values of the bridge alter in proportion to the pressure. The measuring cell is separated from the external pressure by a thin, sensitive stainless steel diaphragm, and the sealed off cavity between diaphragm and cell is filled with oil. Since the standard oil filling is flammable, advises to take precautions when oxygen or any other explosive fluid is used.

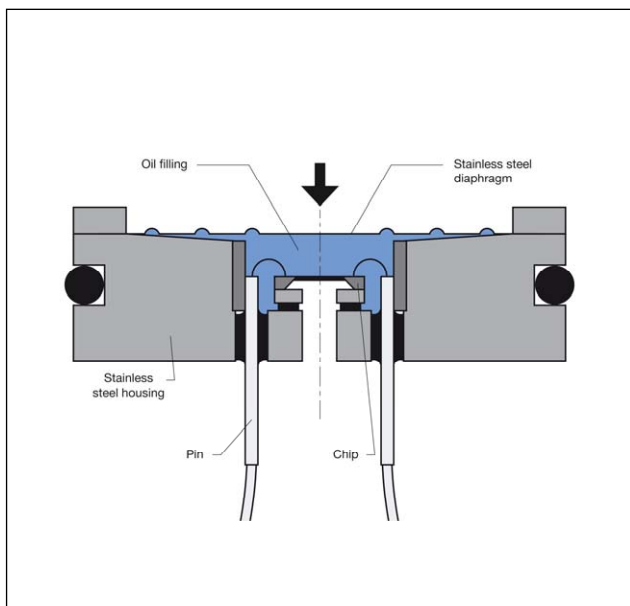

Functional scheme of the pressure sensor

## > State of the art digital design

Today's IN-PRESS series are equipped with a diaphragm type piezo-resistive pressure sensor and a digital pc-board, offering high accuracy, excellent temperature stability and fast response. The basic digital pc-board contains all of the general functions needed for measurement and control. In addition to the standard RS232 and RS485 output, the instruments also offer analog I/O. Furthermore, an optionally integrated interface board provides DeviceNet™, Profibus-DP®, Modbus-RTU or FLOW-BUS protocols via a separate connector.

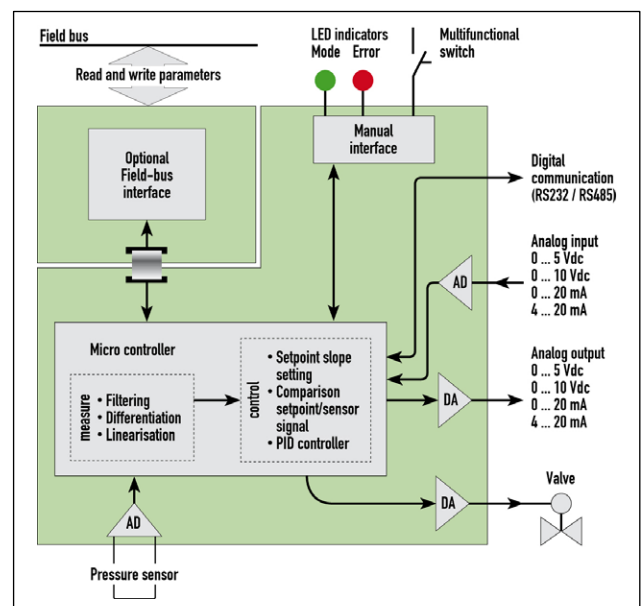

Functional scheme of the digital PC-board

## > Hook-up diagram for analog or RS232 communication

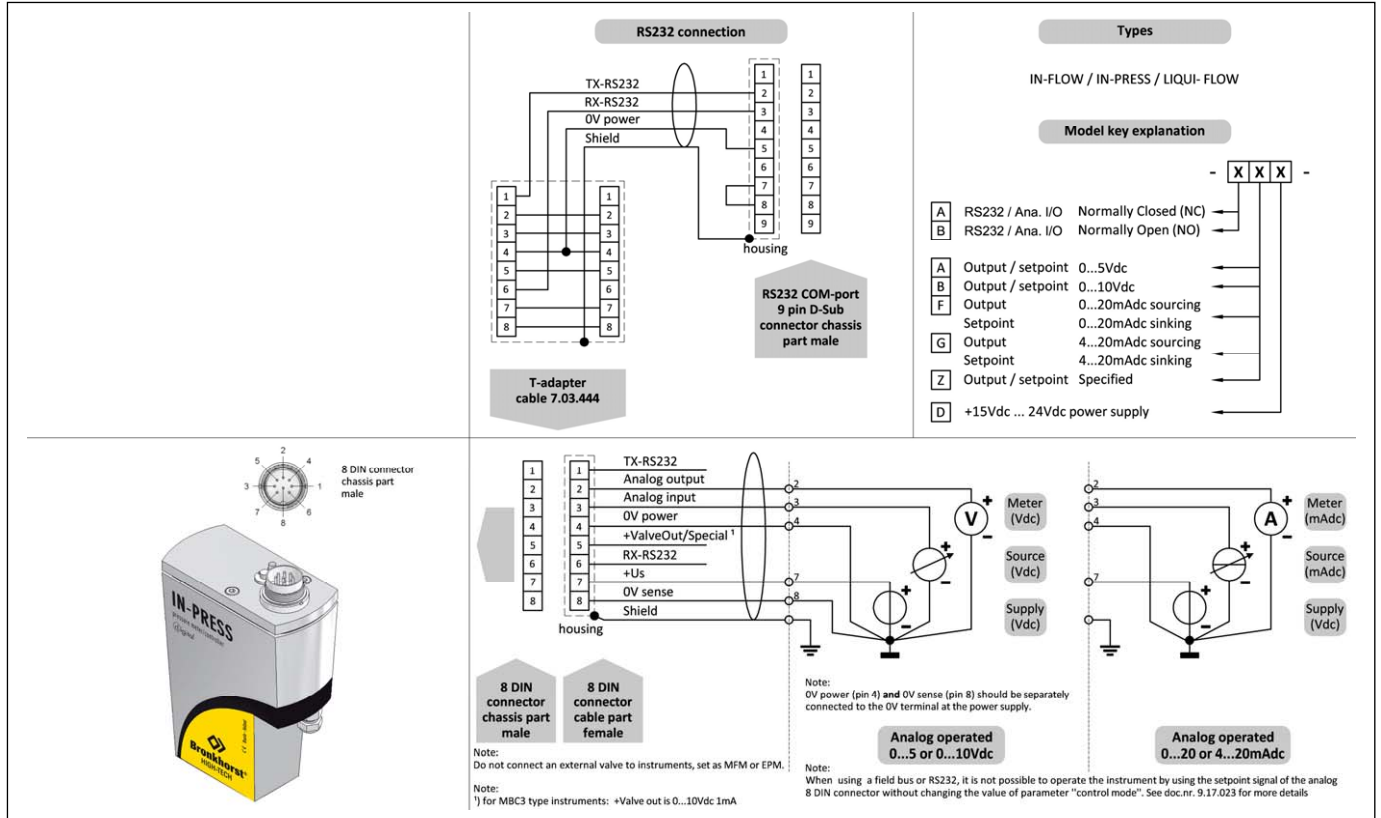

## > Dimensions (mm) and weight (kg)

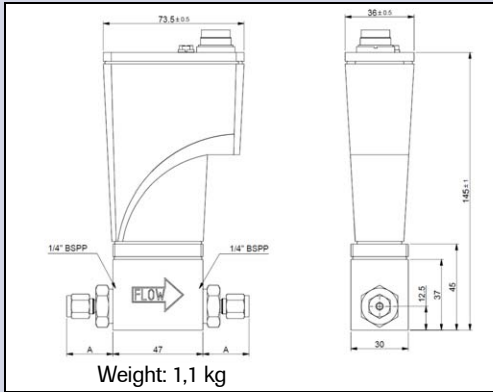

Dimension table adapters (RS-type)

Compression type		1/4" BSPP
		Size A
adapter	3 mm OD	26.1
adapter	6 mm OD	28.4
adapter	8 mm OD	29.4
adapter	10 mm OD	30.2
adapter	12 mm OD	32.5
adapter	1/8" OD	26.1
adapter	1/4" OD	28.4
adapter	3/8" OD	29.9
adapter	1/2" OD	32.7
Face-seal male		Size A
adapter	1/4" inlet	23.2

Compression type

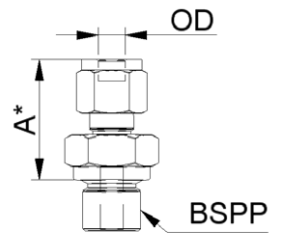

\*) Dimension A is typical finger-tight.

## > Options and accessories

- Free software support for operation, monitoring, optimizing or to interface between digital instruments and windows software.	
- BRIGHT compact local Readout/Control modules - E-5700 / E-7000 Power Supply	
- Interconnecting cables for power and analog/digital communication	

## > Alternatives

- EL-PRESS Pressure Meter with 'laboratory style' (IP40) housing	
- IQ+FLOW, ultra compact Pressure Meter (IP40)	

### По вопросам продаж и поддержки обращайтесь:

Архангельск (8182)63-90-72  
Астана +7(7172)727-132  
Астрахань (8512)99-46-04  
Барнаул (3852)73-04-60  
Белгород (4722)40-23-64  
Брянск (4832)59-03-52  
Владивосток (423)249-28-31  
Волгоград (844)278-03-48  
Вологда (8172)26-41-59  
Воронеж (473)204-51-73  
Екатеринбург (343)384-55-89  
Иваново (4932)77-34-06  
Ижевск (3412)26-03-58  
Иркутск (395) 279-98-46  
Киргизия (996)312-96-26-47

Казань (843)206-01-48  
Калининград (4012)72-03-81  
Калуга (4842)92-23-67  
Кемерово (3842)65-04-62  
Киров (8332)68-02-04  
Краснодар (861)203-40-90  
Красноярск (391)204-63-61  
Курск (4712)77-13-04  
Липецк (4742)52-20-81  
Магнитогорск (3519)55-03-13  
Москва (495)268-04-70  
Мурманск (8152)59-64-93  
Набережные Челны (8552)20-53-41  
Нижний Новгород (831)429-08-12  
Казахстан (772)734-952-31

Новокузнецк (3843)20-46-81  
Новосибирск (383)227-86-73  
Омск (3812)21-46-40  
Орел (4862)44-53-42  
Оренбург (3532)37-68-04  
Пенза (8412)22-31-16  
Пермь (342)205-81-47  
Ростов-на-Дону (863)308-18-15  
Рязань (4912)46-61-64  
Самара (846)206-03-16  
Санкт-Петербург (812)309-46-40  
Саратов (845)249-38-78  
Севастополь (8692)22-31-93  
Симферополь (3652)67-13-56  
Таджикистан (992)427-82-92-69

Смоленск (4812)29-41-54  
Сочи (862)225-72-31  
Ставрополь (8652)20-65-13  
Сургут (3462)77-98-35  
Тверь (4822)63-31-35  
Томск (3822)98-41-53  
Тула (4872)74-02-29  
Тюмень (3452)66-21-18  
Ульяновск (8422)24-23-59  
Уфа (347)229-48-12  
Хабаровск (4212)92-98-04  
Челябинск (351)202-03-61  
Череповец (8202)49-02-64  
Ярославль (4852)69-52-93